

magnaloy

Flexible Drive Couplings Catalog

Connecting Fluid Power for over 60 Years



* Insert color shown is Neoprene (Black)

NOTE: Due to Magnaloy's policy of continuous improvement, specifications are subject to change without notice.

* Check with the factory or our Web Site at www.magnaloy.com for the latest information.

Magnaloy

• 170 N Industrial Hwy. Alpena, MI 49707

• 989 356-2186

www.magnaloy.com

A Division of Douville Johnston Corporation

Catalog No. 2022.5.20 © 2022 Magnaloy

C

FLEXIBLE DRIVE COUPLINGS - SECTION 1

Premium Flexible Drive Couplings2
PM90 Flexible Drive Coupling13

Check out our **Product Configurator Program**

<https://configurator.magnaloy.com>

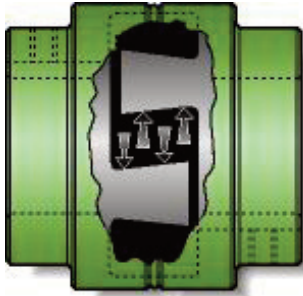

Load-Lock Design...

is simple and effective. The drive lug configuration is tapered from top to base, as are the mating lugs of the opposing coupling hub. Under load, the insert conforms to the tapers, inter-locking the two hubs. This load-lock design protects bearings and equipment by eliminating end thrust in both directions.... and it requires only one set-screw in each hub.

Radial Lug Design...

is logical and efficient. The most common failure of anelastomeric insert type drive coupling is hysteresis failure of the elastomeric element - breakdown of the elastomer due to cyclical overworking and the associated heat generation. Magnaloy Coupling's drive lugs are in a true radial orientation. Applied forces are evenly distributed in the compressive direction only, eliminating the heat generating radial component. True compressive loading reduces internal heat generation and improves elastomer life.

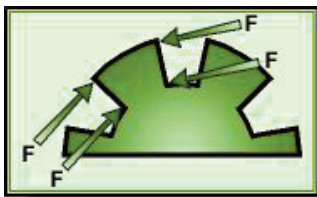
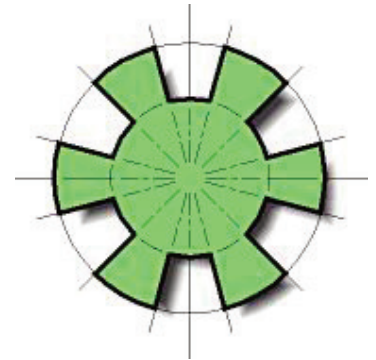

Magnaloy Coupling Design...

Under loaded conditions, the resultant forces applied on the element segments are evenly distributed in the compressive direction only. This results in no radial forces to multiply the internal heat generation.

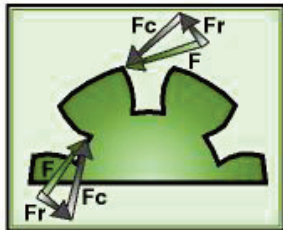

Conventional Design A...

Under loaded conditions this jaw design results in the applied forces exerting components in the compressive and radial directions. These forces change direction and magnitude along the jaw arc which greatly increase the internal movement of the element which causes heat generation.

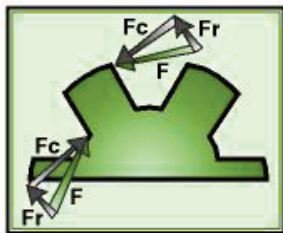

Conventional Design B...

This more conventional straight sided jaw design also exerts component forces in the compressive and radial directions when under load. The radial component is outward (acting to extrude the element) and changes in magnitude only, as does the compressive component, along the jaw surface. The component forces resulting from this design also causes increased internal movement in the element.

A note about Set-Screws ...

The Premium Line of Magnaloy Couplings comes standard with a single set-screw over the keyway. Optional **Double Set-Screws** are available at either 45° or 90° to the keyway. Double set-screws help improve shaft gripping forces by increasing the hoop-stresses generated from tightening a single set-screw. Double set-screws at 45° will produce greater forces than double set-screws at 90°. Either are available upon request by specifying 'DSS45' or 'DSS90' following the hub part number. M30011210DSS45

Magnaloy's Clamp feature is also available with bored and keyed hubs, specify 'C' following the hub part number. M30011210C



Magnaloy is the original lightweight, heavy-duty flexible drive coupling. Light weight magnesium construction makes Magnaloy couplings 76% lighter than cast iron and 36% lighter than aluminum units... and they're stronger than either!

The benefits are many... Reduced loads on bearings, shafts and pumps, for longer component life. Easier handling and installation. Rust proof and corrosion resistant.

Magnaloy's close machining tolerances (TIR of .002") assures vibration-free operation and easy, accurate alignment without need for special tools. Solid magnesium alloy permanent mold castings are heat treated and offer the highest strength-to-weight ratio available.

Coupling Performance Specifications

Coupling Model	Maximum Bore	Wr ² lb-ft ²	Insert Number	Rated Torque lb-in	Torsional Rigidity lb-in/Deg	Horse Power Rating @		
						100 rpm	1200 rpm	1800 rpm
100	1 1/8	0.0046	170N	340.7	42	0.55	6.5	9.8
			170U	511.0	53	0.82	9.8	14.7
			170H	1,022.1	182	1.65	19.8	29.7
200	1 3/8	0.0068	270N	398.3	55	0.64	7.6	11.5
			270U	597.4	68	0.96	11.5	17.2
			270H	1,194.9	234	1.92	23.0	34.5
300	1 5/8	0.022	370N	701.4	81	1.12	13.5	20.2
			370U	1,052.1	148	1.68	20.2	30.3
			370H	2,104.2	336	3.36	40.4	60.6
400	1 7/8	0.031	470N	1,056.3	138	1.69	20.3	30.4
			470U	1,584.5	310	2.50	30.4	45.6
			470H	3,168.9	488	5.10	60.8	91.3
500	2 3/8	0.071	570N	2,194.8	314	3.50	42.1	63.2
			570U	3,292.2	695	5.30	63.2	94.8
			570H	6,584.4	1,571	10.50	146.4	189.6
600	2 5/8	0.16	670N	4,946.7	676	7.90	94.9	142.5
			670U	7,420.1	1,510	11.90	142.5	213.7
			670H	14,840.1	2,960	23.70	284.9	427.4
700	2 7/8	0.34	770N	11,639.8	1,805	18.60	223.5	335.2
			770U	17,459.7	2,104	27.90	335.2	502.8
			770H	29,099.5	5,960	46.50	558.8	838.0
800	3 7/8	0.95	870N	21,889.4	3,680	35.00	420.3	630.4
			870U	32,834.1	-	52.50	630.4	945.6
			870H	47,062.2	11,950	75.20	903.0	1,354.5
900	4 3/4	4.20	970N	47,842.3	8,428	76.50	918.6	1,377.9
			970U	71,763.5	-	114.80	1,377.9	2,066.8

Magnaloy Coupling Dimensional Specifications

Models 100, 200, 300, 400

	100	200	300	400
A	2.54	3.10	3.58	4.24
B	2.600	2.900	3.450	3.980
C	2.00	2.25	2.90	3.05
D	0.56	0.68	0.78	1.00
E	0.68	0.84	0.96	1.06
F	0.42	0.42	0.44	0.54
G	0.31	0.43	0.56	0.73
W	1/16	1/16	1/16	1/16
X	0.90	0.90	0.98	1.20
T	1/4-20	5/16-18	5/16-18	3/8-16

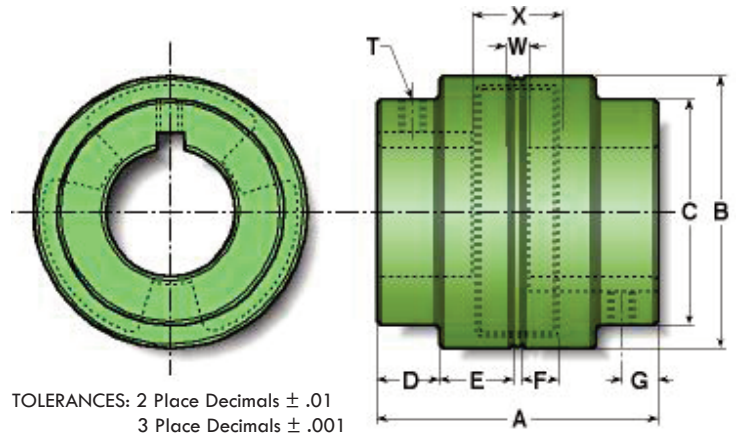

Model 500

	500
A	4.67
B	4.800
C	4.00
D	1.04
E	1.23
F	0.64
G	0.70
W	1/16
X	1.41
T	3/8-16

X*: Maximum Space between shaft ends to allow full shaft engagement in Hub Bore.

W*: Minimum Space between shaft ends.

* Given for reference only.

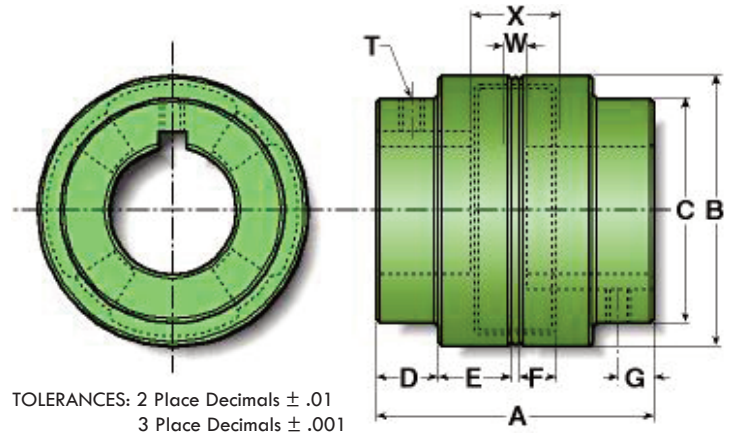

Models 600, 700, 800, 900

	600	700	800	900
A	5.98	6.99	7.99	10.15
B	5.975	6.900	8.600	11.400
C	4.50	5.19	7.00	8.30
D	1.60	2.08	2.25	2.75
E	1.33	1.32	1.62	2.20
F	0.62	0.89	1.00	1.32
G	1.13	1.13	1.58	1.88
W	1/16	1/16	1/16	1/16
X	1.36	1.97	2.25	2.89
T	3/8-16	1/2-13	1/2-13	3/4-10

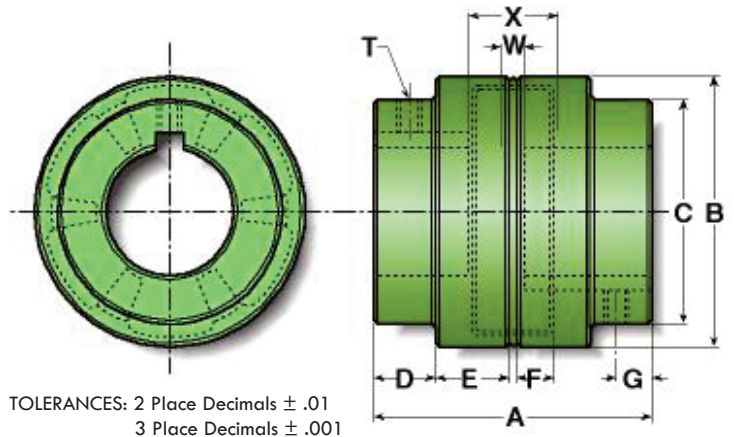

Standard Bore and Keyway Combinations

Magnaloy "Standard" Bore Key Combinations												
Model Code	Bore/Key Code	Model		100	200	300	400	500	600	700	800	900
		Bore	Key									
M	01203	3/8	x 3/32	*	*							
M	01403	7/16	x 3/32	*	*							
M	01404	7/16	x 1/8	*	*							
M	01604	1/2	x 1/8	*	*	*						
M	01804	9/16	x 1/8	*	*	*						
M	02005	5/8	x 5/32	*	*	*						
M	02006	5/8	x 3/16	*	*	*	*					
M	02206	11/16	x 3/16	*	*	*	*					
M	02404	3/4	x 1/8	*	*	*						
M	02406	3/4	x 3/16	*	*	*	*	*				
M	02806	7/8	x 3/16	*	*	*	*	*	*			
M	02808	7/8	x 1/4	*	*	*	*	*	*			
M	03008	15/16	x 1/4	*	*	*						
M	10006	1	x 3/16	*	*	*	*	*	*			
M	10008	1	x 1/4	*	*	*	*	*	*			
M	10408	1 1/8	x 1/4	*	*	*	*	*	*			
M	10608	1 3/16	x 1/4			*	*	*	*			
M	10808	1 1/4	x 1/4			*	*	*	*			
M	10810	1 1/4	x 5/16			*	*	*	*	*	*	
M	11210	1 3/8	x 5/16			*	*	*	*	*	*	
M	11212	1 3/8	x 3/8			*						
M	11412	1 7/16	x 3/8			*	*	*				
M	11610	1 1/2	x 5/16				*	*	*			
M	11612	1 1/2	x 3/8			*	*	*	*	*		
M	12012	1 5/8	x 3/8			*	*	*	*	*	*	
M	12412	1 3/4	x 3/8			*	*	*	*	*	*	

Magnaloy "Standard" Bore Key Combinations												
Model Code	Bore/Key Code	Model		100	200	300	400	500	600	700	800	900
		Bore	Key									
M	12414	1 3/4	x 7/16				*	*	*	*	*	*
M	12816	1 7/8	x 1/2				*	*	*	*	*	*
M	13016	1 15/16	x 1/2				*	*	*	*	*	*
M	20016	2	x 1/2				*	*	*	*	*	*
M	20416	2 1/8	x 1/2				*	*	*	*	*	*
M	20816	2 1/4	x 1/2				*	*	*	*	*	*
M	21220	2 3/8	x 5/8				*	*	*	*	*	*
M	21620	2 1/2	x 5/8					*	*	*	*	*
M	22020	2 5/8	x 5/8					*	*	*	*	*
M	22420	2 3/4	x 5/8						*	*	*	*
M	22824	2 7/8	x 3/4						*	*	*	*
M	30024	3	x 3/4							*	*	*
M	30824	3 1/4	x 3/4							*	*	*
M	31228	3 3/8	x 7/8							*	*	*
M	31628	3 1/2	x 7/8							*	*	*
M	32028	3 5/8	x 7/8							*	*	*
M	32428	3 3/4	x 7/8							*	*	*
M	32832	3 7/8	x 1							*	*	*
M	40032	4	x 1								*	*
M	40432	4 1/8	x 1								*	*
M	40832	4 1/4	x 1								*	*
M	41232	4 3/8	x 1								*	*
M	41632	4 1/2	x 1								*	*
M	41640	4 1/2	x 1 1/4								*	*
M	42040	4 5/8	x 1 1/4								*	*
M	42440	4 3/4	x 1 1/4								*	*

Shaded Area: AGMA semi-standard bore key combinations.

Part Number Usage: Magnaloy Coupling Hub part numbers may be specified using the following format: Start with letter "M" designating Magnaloy, followed by 3 digit Model Code (100, 200, etc.), then the specific 5 digit Bore/Key Code.

Example: Model 500 Hub with a 1 3/8 bore and 5/16 keyway would be specified as: M50011210 - No bore hubs are designated as "R" code, ie. M500R.

Bore Tolerances

Over	Include	Tolerance
--	1	+0.0008/+0.0003
1	2	+0.0013/+0.0005
2	3	+0.0018/+0.0008
3	4	+0.0020/+0.0010
4	5	+0.0023/+0.0010

Additional Coupling Specifications

Model Number	100	200	300	400	500	600	700	800	900
Maximum Bore	1 1/8	1 3/8	1 5/8	1 7/8	2 3/8	2 5/8	2 7/8	3 7/8	4 3/4
Complete Coupling Approx. Weight (Solid Hub)	3/4	1	2	3	4	7	12	18	38
Number of Drive Lugs	3	3	3	3	4	6	6	6	6
Hub Movement for Insert Removal	.74	.74	.75	.98	1.12	1.02	1.50	1.63	2.27
Basic Insert Number	170	270	370	470	570	670	770	870	970

Metric Bore and Key Combinations

Standard Metric Bore and Keyway Combinations

Magnaloy "Standard" Bore Key Combinations										
Model Code	Bore/Key Code	Model		100	200	300	400	500	700	900
		Bore	Key							
M ___	M0602	6	x 2	*	*					
M ___	M1003	10	x 3	*	*	*				
M ___	M1204	12	x 4	*	*	*				
M ___	M1405	14	x 5	*	*	*				
M ___	M1505	15	x 5	*	*	*	*			
M ___	M1605	16	x 5	*	*	*	*			
M ___	M1806	18	x 6	*	*	*	*	*		
M ___	M1906	19	x 6	*	*	*	*	*		
M ___	M2006	20	x 6	*	*	*	*	*	*	
M ___	M2408	24	x 8	*	*	*	*	*	*	
M ___	M2508	25	x 8	*	*	*	*	*	*	*
M ___	M2808	28	x 8	*	*	*	*	*	*	*
M ___	M3210	32	x 10		*	*	*	*	*	*
M ___	M3510	35	x 10		*	*	*	*	*	*

Magnaloy "Standard" Bore Key Combinations										
Model Code	Bore/Key Code	Model		100	200	300	400	500	700	900
		Bore	Key							
M ___	M3810	38	x 10			*	*	*	*	*
M ___	M4012	40	x 12			*	*	*	*	*
M ___	M4212	42	x 12			*	*	*	*	*
M ___	M4814	48	x 14			*	*	*	*	*
M ___	M5014	50	x 14			*	*	*	*	*
M ___	M5516	55	x 16			*	*	*	*	*
M ___	M6018	60	x 18			*	*	*	*	*
M ___	M6518	65	x 18			*	*	*	*	*
M ___	M7020	70	x 20			*	*	*	*	*
M ___	M7520	75	x 20			*	*	*	*	*
M ___	M8022	80	x 22			*	*	*	*	*
M ___	M9025	90	x 25			*	*	*	*	*
M ___	M9525	95	x 25			*	*	*	*	*
M ___	M10028	100	x 28			*	*	*	*	*

Note: Custom combinations are also available. Contact Factory.

Part Number Usage: Magnaloy Coupling Hub part numbers may be specified using the following format: Start with letter "M" designating Magnaloy, followed by 3 digit Model Code (100, 200, etc.), "M" for metric, then the specific 4-5 digit Bore/Key Code.

Example: Model 500 Hub with a 40mm bore and 12mm keyway would be specified as: M500M4012.

Bore Tolerances

Over	Include	Tolerance
--	1	+0.008/+0.003
1	2	+0.013/+0.005
2	3	+0.018/+0.008
3	4	+0.020/+0.010
4	5	+0.023/+0.010



Magnaloy Couplings are available with a variety of special features which include splined bores. The “Splined Coupling Specifications” chart on page 7 shows several “In-house” splines available for quick delivery. Many additional splined bores are available by contacting the factory, including straight sided “PTO” type splines and metric splines.



The Clamp-Type Coupling utilized the basic Magnaloy coupling with the addition of the clamp feature. Developed to compensate for variations in spline formation methods and tolerances. Assures centering of the coupling and positive retention on the shaft. The clamp feature is suggested for all splined couplings, but is also available in smooth bored and keyed models.



Magnaloy’s Steel Bushed Splined Bore* Coupling combines all the design and lightweight features of the Magnaloy Coupling with the added spline tooth strength and wear resistance of steel. Under normal conditions the standard “Splined Bore” coupling will perform satisfactorily and the addition of the “Clamp Feature” compensates for various fit conditions. When heavy cyclic loads, reverse loading and high torque loads exist in combination with fit variations, spline tooth failures and fretting can be corrected by utilizing Magnaloy’s steel bushed coupling. Of course, to achieve optimum benefits, Magnaloy’s clamp feature is recommended - assuring accurate centering and positive retention of the coupling on the shaft.

** Although the steel bushing feature was designed primarily for spline bores, it is also available in smooth bored and keyed sizes.*

Splined & Clamp Specifications

Spline Coupling Specifications

Spline Size			Pressure Angle (Degrees)	SAE Designation	Major Diameter (Inches)	Std Coupling Available Model Sizes	Steel Bushed Coupling	
Number of Teeth	Pitch Ratio	Spline Code					Bushing Diameter	Available Model Sizes
9	16/32	0916	30°	A	0.625	100 - 900	1.250	200 - 600
13	8/16	1308	30°	D, E	1.750	400 - 900	2.625	600 - 900
13	16/32	1316	30°	B	0.875	100 - 900	1.500	300 - 800
14	12/24	1412	30°	C	1.250	200 - 900	2.250	500 - 900
15	8/16	1508	30°	F	2.000	500 - 900	3.500	800 - 900
15	16/32	1516	30°	BB	1.000	100 - 900	1.750	400 - 800
17	12/24	1712	30°	CC	1.500	300 - 900	2.250	500 - 900
21	16/32	2116	30°		1.375	300 - 900	2.250	500 - 900
23	16/32	2316	30°		1.500	300 - 900	2.250 ¹	500 - 900
27	16/32	2716	30°		1.750	400 - 900	2.625 ²	600 - 900
40	16/32	4016	30°		2.562	600 - 900	3.875	800 - 900

Note:

- 1 - With Model 600 - 900, Bushing O.D. is 2.625.
- 2 - With Model 700 & 800, Bushing O.D. is 2.875.

Spline Type Identifier Code: A = Spline, B = Steel Bushing
Clamp Type Code: C = Clamp Type.

Part Number Usage: Magnaloy Splined Coupling part numbers may be specified using the following format: Start with letter “M” designating Magnaloy, follow with 3 digit Model Code (100, 200, etc.), next use a single letter Spline Type Identifier Code (“A” for regular spline or “B” for steel bushing), then the specific 4 digit Spline Code. If a clamp type coupling is desired, use the letter code “C” after the Spline Code.

Examples: Model 300 hub with 13 tooth 16/32 splined bore: M300A1316. Same item with steel bushing: M300B1316. Same item with steel bushing and clamp: M300B1316C.

Clamp Type Coupling Specifications

Coupling Model	Bolt Location		U	
	Z	Y	Bolt Size	Torque Spec.
100	0.31	0.68	1/4 - 20	130-140 in lbs
200	0.43	0.75	1/4 - 20	130-140 in lbs
300	0.47	0.95	5/16 - 18	210-220 in lbs
400	0.69	0.106	5/16 - 18	210-220 in lbs
500	0.72	1.25	3/8 - 16	300-310 in lbs
600	1.13	1.50	7/16 - 14	35-36 ft lbs
700	1.13	1.75	7/16 - 14	35-36 ft lbs
800	1.30	2.56	1/2 - 13	49-50 ft lbs
900*	0.75 & 2.19	3.00	3/4 - 10	100-110 ft lbs

* Model 900 utilizes two bolt clamp design.

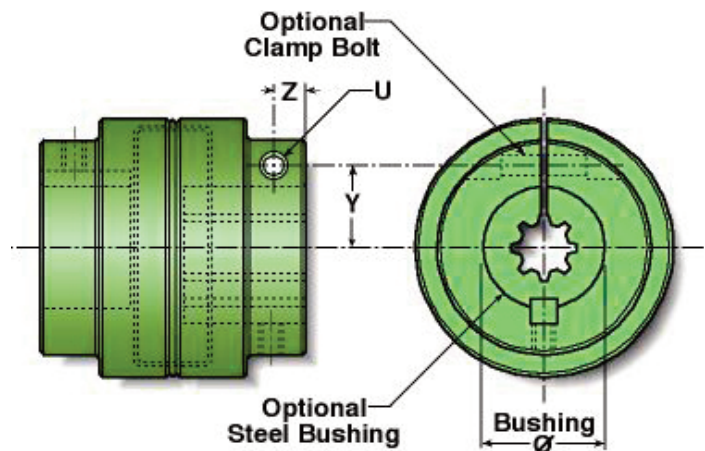

Magnaloy Coupling's full range of flexible inserts permit custom design performance for a wide range of applications. All insert materials offer complete electrical insulation, as Magnaloy's design eliminates all metal-to-metal contact.



1

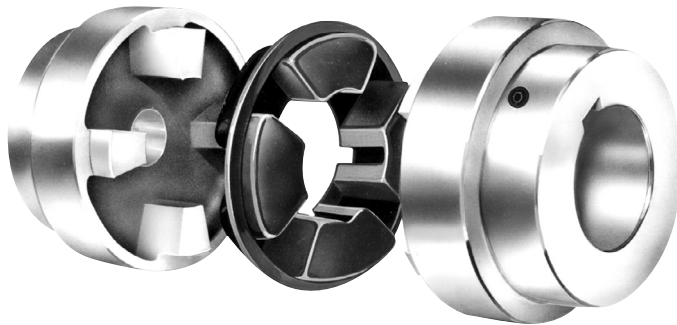

Part Number Usage: Magnaloy Coupling Insert part numbers may be specified using the following format: Start with the letter "M" for Magnaloy, followed by the 3 digit Basic Insert Number Code (170, 270, etc.), then the specific single letter Insert Material Code. If an optional durometer is being specified, after the Material Code supply the durometer number divided by 10.

Examples: Urethane insert for Model 300: M370U. 80 Durometer Neoprene for Model 200: M270N8.

Neoprene (Code N) - Black material - Standard material with Magnaloy Coupling. Good general purpose material offering good resiliency and load capabilities. Temp range -30°F to +250°F (-34°C to +121°C). Optional 80A durometer (painted Gold) and 90A durometer (painted Silver) are available for slight increased load capability and less resiliency.

Nitrile (Buna N)(Code B) - Painted Blue. Excellent material with petroleum products. Excellent compression set and abrasion resistance characteristics. Temp range -60°F to +250°F (-51°C to +121°C).

Urethane (Code U) - Yellow material. Excellent mechanical and physical properties. Offers good medium duty durability and resiliency. Urethane tends to soften at higher temperatures and humid conditions. Temp range -30°F to +150°F (-34°C to +66°C).

Viton (Fluorocarbon)(Code V) - Red material. Excellent fluid compatibility and high temperature characteristics. Good compression set and resiliency. Temp range -20°F to +350°F (-29°C to +177°C).

Hytrel (Code H) - Blue material. Superior physical and mechanical properties and excellent fluid compatibility and high temperature characteristics. Hardness (50D) approaches that of plastic and offers little resiliency. Excellent performance under heavy duty conditions. Temp range -65°F to +300°F (-54°C to +149°C).

Other materials are available for special applications. Consult factory for recommendations and availability.

Service Factors - Load Characteristics

Load Classification	Type of Prime Mover			
	Standard Motor or Turbine	High Torque Motor	I.C. Engine 6 or more cyl.	I.C. Engine less than 6 cyl.
Uniform (U)	1.0	1.5	1.5	2.0*
Moderate (M)	1.5	2.0	2.0	2.5*
Heavy (H)	2.0*	2.5*	2.5*	3.0*

Uniform Load: Steady loading, non-reversing, torque does not exceed rating.

Moderate Load: Uneven loading with moderate shock, frequent starts, infrequent reversals, peak torque may exceed average rating of prime mover by up to 125%.

Heavy Load: Uneven loading with heavy shock, frequent reversals, peak torque may exceed average rating of prime mover by up to 150%.

* Recommend use of Hytrel Insert.

Drive Unit	Load Sym.
Agitators	U
Blowers	U
Compressors - Centrifugal	U
- Rotary	M
- Reciprocating	H*
Conveyors -	U
- Reciprocating	M
- Screw	M
- Shaker	H
Cranes & Hoists	M
Crushers	H*
Elevators	M
- Freight & Pass.	H*
Fans - Centrifugal	U
- Propeller	M
- Cooling Tower	H
Generators	U
- Welding	H
Mills	H*
Machine Tools	M
Mixers	M
Paper Mill Machinery	M
Pumps - Centrifugal	U
- Rotary	M
- Reciprocating	H*
- On Injection Molding Equip.	H*
Screens - Air & Water Washing	U
- Freight & Pass.	H
Stokers	U
Textile Machinery	M
Woodworking Machinery	M
Winches	H*

Selection Method
<p>1. Several specifics must be considered to make the best choice of couplings:</p> <p>A. Type of prime mover and load characteristics (see table above)</p> <p>B. Shaft diameter and key size or spline configuration (No. of teeth, pitch ratio, pressure angle)</p> <p>C. Horsepower rating of loads to be transmitted.</p> <p>D. Maximum operating speed (rpm)</p> <p>E. Maximum operating misalignment</p> <p>F. Clearance limitations</p> <p>2. Calculate effective hp/100 rpm by use of table above and select the minimum size coupling recommended</p> <p>3. VERIFY YOUR SELECTION:</p> <p>A. Check for maximum bore size</p> <p>B. Check dimensions for adequate clearance</p> <p>C. Indicate any special insert specification and/or coupling coating for environmental protection, if required</p> <p>Equation: Effective HP per 100 RPM = rated HP x Service Factor x 100 / RPM</p> <p>Example: 150 HP, 4 cyl. Diesel Engine Driving a Reciprocating Irrigation Pump operating at 3250 RPM Service Factor - 3.0 (Hytrel Insert Recommended) Eff. HP per 100 RPM = 150 HP x 3.0 x 100 / 3250 RPM = 13.85 HP/100 RPM. Model 600 rating with Hytrel Insert is 23.7 HP/100 RPM.</p>

Note: Above service factors are intended for use as a general guide only.

*Recommend use of Steel Bushing and Clamp with Splined Bores.



Shaft spacing should be within range given by dimensions 'W' and 'X' as shown in charts on page 3.

Position each hub on proper size shaft - Magnaloy couplings are bored to standard "push fit" tolerances, if a tight fit exists, check shaft for burrs.

Maximum benefits are obtained with hubs positioned to allow complete shaft engagement within bore. However, some equipment designs do not permit this condition - maximum shaft engagement should be utilized in any case.

Alignment - Place a straight edge (scale) at top and side of coupling. Use a .005 inch feeler gauge under scale for final inspection. This will indicate accurate parallel and angular alignment.

Magnaloy's precision machined outside surfaces permit this simple, but accurate alignment method.



Secure equipment mounts and recheck alignment for movement.

Install the insert in the coupling positioning hubs in contact with lip around outside of insert.

Before tightening set screws, run the coupling and check for separation of hubs or "creep". Recheck alignment and tighten set screws.

With the Steel Bushed/Clamp type couplings, to facilitate installation on the shaft, it may be necessary to slightly loosen the set-screw over the keystone. When securing the coupling on the shaft, first tighten the clamp bolt, then tighten the set-screw against the keystone.

Mis-Alignment Capabilities

Magnaloy Couplings offer four-way flexibility (parallel, angular, axial and torsional) and require no lubrication. They are easily installed and properly aligned without use of special tools or equipment - a straight edge and hex wrench are the only tools required. Magnaloy's insert reduces noise and vibration and permits needed flexibility for proper operation within alignment capabilities.

Recommended Torques for Fasteners

Model	Set Screw	Clamp Screw
100	60 - 70 in lbs	130 - 140 in lbs
200	75 - 85 in lbs	130 - 140 in lbs
300	75 - 85 in lbs	210 - 220 in lbs
400	190 - 200 in lbs	210 - 220 in lbs
500	190 - 200 in lbs	300 - 310 in lbs
600	190 - 200 in lbs	35 - 36 ft lbs
700	300 - 310 in lbs	35 - 36 ft lbs
800	300 - 310 in lbs	49 - 50 ft lbs
900	100 - 110 ft lbs	100 - 110 ft lbs

Intended as a general guide for fastener torques with Magnaloy Couplings.

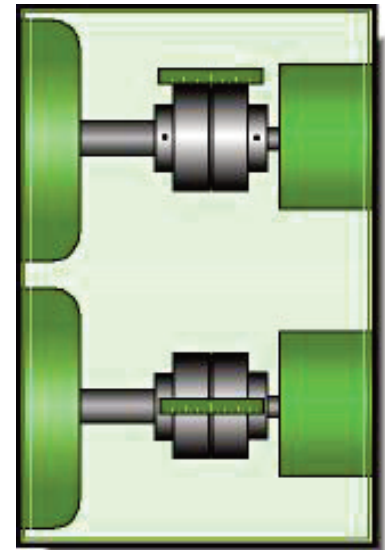

1

Perfect alignment of equipment shafts, in most cases, is impractical to obtain or maintain, and misaligned equipment produces, excess stress on bearings and the coupling. Magnaloy's insert design will accept misalignment strain and, when excessive, will cause insert wear as a visual and audible indication of misalignment problems. However, Magnaloy's inserts are inexpensive and easily replaces; under normal conditions the insert seldom requires replacement.

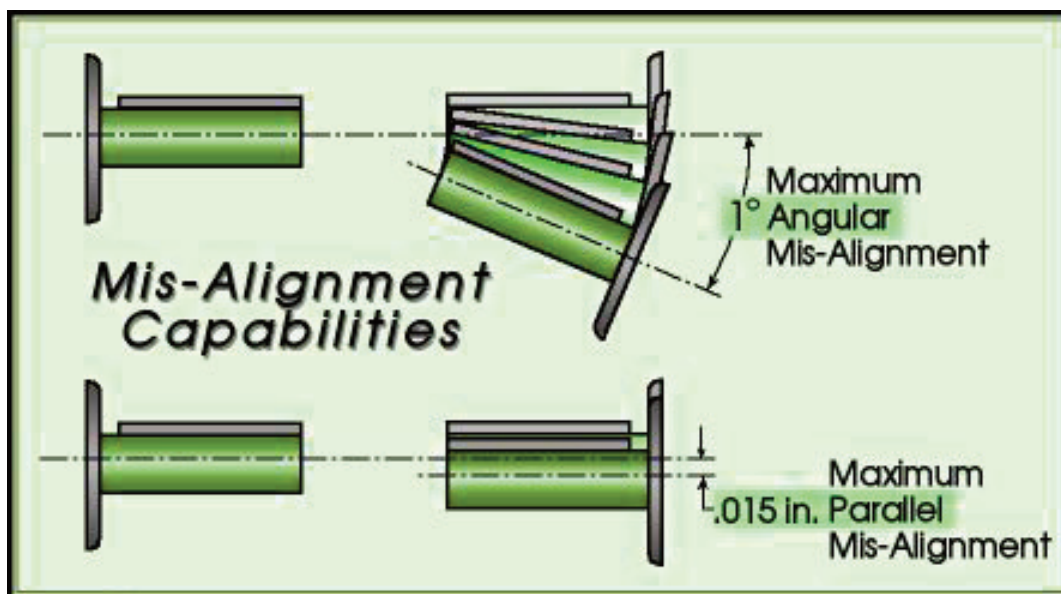

Keystock Interference with Drive Lug

Since the Magnaloy Coupling keyway, in a bored and keyed hub, is broached between the drive lugs, there is a potential for interference with the keystock of the drive hub and the drive lugs of the opposing hub. This interference will result when ALL the following conditions exist:

- A) The shaft diameter is Greater than listed below
- B) This shaft extends into the hub insert core area
- C) The keystock on this shaft extends with the shaft into the insert core area

1

The interference condition can be corrected by shortening the keystock so it does not extend into the insert core area. The keystock length should be limited to the length of the coupling hub bore.

Interference Potential exists when shaft diameters are greater than shown in this chart.

Model Size	Shaft Diameter	Key Size
100	7/8	1/4
200	1 3/16	1/4
300	1 5/16	5/16
400	1 1/2	3/8
500	1 15/16	1/2
600	2 1/2	5/8
700	2 3/4	5/8
800	3 1/2	7/8
900	4 1/2	1 1/4

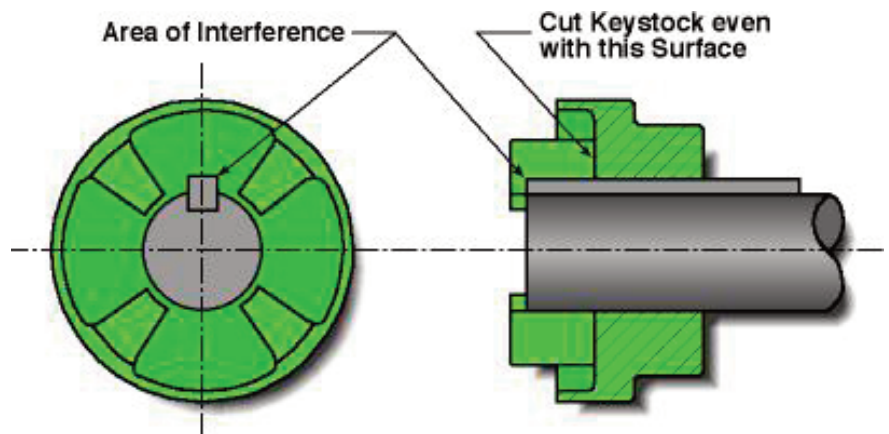

Failure to correct this condition will result in assembly difficulty and could cause damage to the drive or driven equipment. Check our web site at www.magnaloy.com for other bulletins.

Powdered Metal PM90 Coupling

The Strong, High Quality, Low Cost Powdered Metal Coupling from Magnaloy

When your priorities for a coupling are economy and strength... specify the all-new Magnaloy Type PM90.

The PM90 is made from high-density powdered metal and is available in standard bores up to 1 1/8 inch maximum. Double set screws are standard in all bores 1/2 inch and over. The set screws are placed over the keyway and at a 45° angle to the keyway to allow greater hoop-stress generation and maximum shaft gripping. The increased drive lug surface area on the PM90 provides low unit loads on the insert drive segments while insuring more rapid heat dissipation. Magnaloy's exclusive insert design allows easy installation and replacement without hub removal. The drive lug design provides even compressive loading with no radial loading of insert drive elements.

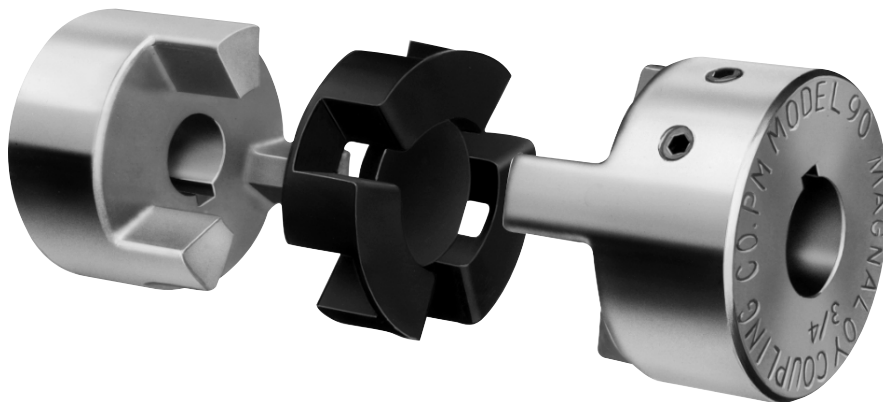

It is a well established fact that the major cause of failure in an elastomeric insert type drive coupling is hysteresis failure which results from overworking the insert by application of cyclic loads and the associated heat generation. These cyclic loads can be internal in origin as a result of coupling design (see page 1) and when coupled with externally applied loads can greatly reduce elastomer life. Specifying Magnaloy's Type PM Coupling with radial designed drive lugs results in true compressive loads and improved insert life.

Model PM90 Performance Specifications

Maximum Bore	Minimum Bore	Insert Number	Torque Rating (in lb)	HP Rating per 100 RPM	Torsional Rigidity (in lb/deg)	Complete Coupling Approx Weight (lb)		Wr ² (lb ft ²) (solid)
						Solid	Max Bore	
1 1/8	7/16	P097N7	224	0.36	38.3	1.8	1.3	0.946
		P097U9	336	0.54	69.9			
		P097H5	672	1.08	158.7			

1

Model PM90 Dimensional Specifications

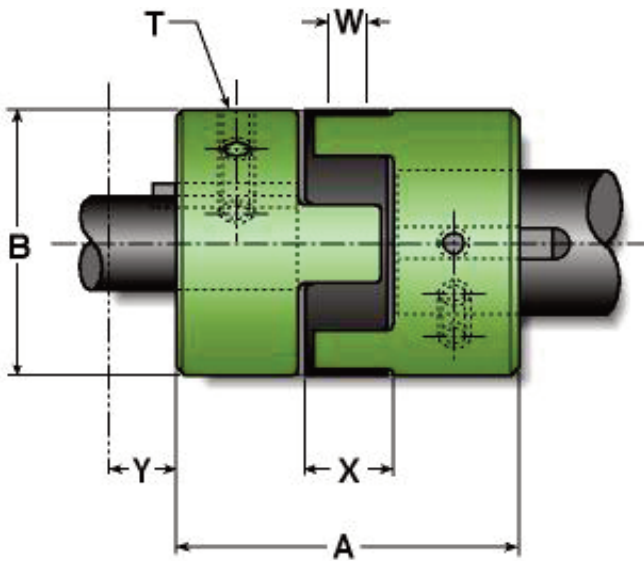

A	Over all length (Assembled) - 2.78
B	Outside Diameter - 2.125
T	Set Screw Size - 1/4-20 UNC, 2 places
W	Distance between shaft ends - 3/16 min
X	Distance between shaft ends - 3/4 max
Y	Hub movement required for insert removal - 1.20 total

Model PM90 - Standard Bore / Keyway Sizes (per AGMA Class 1, Clearance Fit)

Part Number	Bore & Keyway Combinations	Bore Size**	Key Width	Key Depth	Set Screw	
					Size	Quantity
P090014N	7/16 x No Key	0.4375 / 0.4385	-	-	1/4-20 UNC	1
P09001403	7/16 x 3/32	0.4375 / 0.4385	0.0938 / 0.0958	0.484 / 0.495	1/4-20 UNC	1
P09001404	7/16 x 1/8	0.4375 / 0.4385	0.125 / 0.127	0.496 / 0.507	1/4-20 UNC	2
P09001604	1/2 x 1/8	0.500 / 0.501	0.125 / 0.127	0.560 / 0.571	1/4-20 UNC	2
P09001804	9/16 x 1/8	0.5625 / 0.5635	0.125 / 0.127	0.623 / 0.634	1/4-20 UNC	2
P09002005	5/8 x 5/32	0.625 / 0.626	0.1562 / 0.1582	0.698 / 0.709	1/4-20 UNC	2
P09002006	5/8 x 3/16	0.625 / 0.626	0.1875 / 0.1895	0.709 / 0.720	1/4-20 UNC	2
P09002206	11/16 x 3/16	0.6875 / 0.6885	0.1875 / 0.1895	0.773 / 0.784	1/4-20 UNC	2
P09002404	3/4 x 1/8	0.750 / 0.751	0.125 / 0.127	0.812 / 0.823	1/4-20 UNC	2
P09002406	3/4 x 3/16	0.750 / 0.751	0.1875 / 0.1895	0.837 / 0.848	1/4-20 UNC	2
P09002806	7/8 x 3/16	0.875 / 0.876	0.1875 / 0.1895	0.964 / 0.975	1/4-20 UNC	2
P09002808	7/8 x 1/4	0.875 / 0.876	0.250 / 0.252	0.982 / 0.993	1/4-20 UNC	2
P09010006	1 x 3/16	1.000 / 1.001	0.1875 / 0.1895	1.090 / 1.101	1/4-20 UNC	2
P09010008	1 x 1/4	1.000 / 1.001	0.250 / 0.252	1.114 / 1.125	1/4-20 UNC	2
P09010408	1 1/8 x 1/4	1.125 / 1.126	0.205 / 0.252	1.241 / 1.252	1/4-20 UNC	2

* Shaded combinations are Semi-special - see price sheet

** Other Bore/Keyway combinations are available. Consult factory for quotation.

Model PM90 Bore Tolerances

Feature	Tolerance
Bore	-.000 / +.001
Key Width	-.000 / +.002
Key Depth	+.005 / +.016

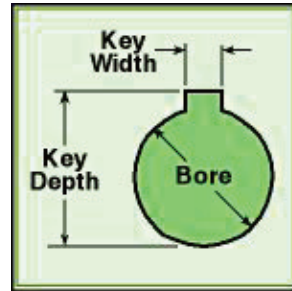

As with Magnaloy's standard line of couplings, insert elastomer selection allows variable performance characteristics. Insert design eliminates metal-to-metal contact and assures electrical isolation of shafts.

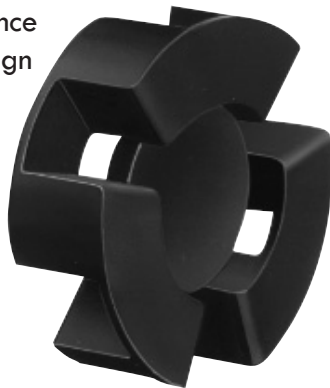

Nitrile, 70A Durometer....

Standard elastomer material offering excellent resistance to petroleum products and superior compression set characteristics.

Urethane, 90A Durometer....

Excellent mechanical and physical properties. *Note:* Urethane material tends to soften when exposed to elevated temperatures or humid conditions.

Hytrel, 50D Durometer....

Superior mechanical and physical properties and offers excellent fluid compatibility and high temperature characteristics.

Additional insert materials available upon request from factory.

See page 8 for additional information on insert selection.

Make the Connection with magnaloy

Whatever your Fluid Power Unit needs,
Magnaloy has the products
to keep you connected.



Flexible Drive Couplings

Top-of-the-line magnesium couplings are lighter, yet stronger than either cast iron or aluminum. They also offer better corrosion resistance and easier handling.



Magnaloy Hydraulic Bar Manifolds & Accessories

Complete line of inline Bar Manifolds, Subplates, Cover Plates, Valve Adaptors, Integrated Circuit Manifolds, and Accessories to make the design and fabrication of Hydraulic Circuitry simple and easy. Wide range of sizes include: D03, D05, D05H & D08 in aluminum and steel with ports available in SAE, NPTF, BSPP, and BSPT styles. Custom design and fabrication also available, consult factory.

Accessories

Filler Breather Adaptors, Filler Breathers, Reservoir Flanges, Suction Strainers, Gauge Isolators, Liquid Level Gauges, Modular O-Ring Kits.



Pump/Motor Mounts

Precision machined aluminum & custom steel pump/motor mounts directly connect the motor and pump while ensuring accurate shaft alignment and enclosing the coupling. Vertical and horizontal models readily available from stock.



Rod End Couplers

Two models of accurately machined high tensile cylinder rod end alignment couplers offer 7° or 10° spherical and 1/8" parallel misalignment capabilities.



PM 90 Couplings

Economical PM-90 Iron Powder Couplings have long lasting nitrile, hytrel or urethane inserts. Double set screws give excellent gripping power.

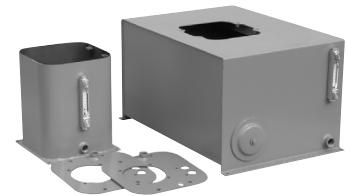

Magnaloy Reservoirs & Reservoir Accessories

Magnaloy offers a complete line of standard reservoirs and reservoir accessories. In addition, we offer custom reservoir fabrication to meet our customer specific needs. Reservoir accessories such as Clean Out Covers and SAE Couplings are available for the "do-it-yourself" reservoir manufacturer.



Magnaloy Pressure Switch

Pressure Sensing switch capable of sensing up to three (3) separate pressures. Each sensor is externally independently adjustable from 200 to 4000 psi. Viton seals provide wide fluid compatibility range.